

# POWER SOLAR SERIES

**POWER**   
Power for a World of Applications

## PSG-12105

**VALVE REGULATED LEAD ACID BATTERY  
(V.R.L.A.)**

**ADVANCED GEL TECHNOLOGY  
(AGM + GEL)**

**SUPERIOR DISCHARGE PROFILE**

The Power Solar Advanced Gel batteries are designed and manufactured to handle every aspect of the demanding solar industry. The PSG series is built to withstand the wide range of environments, storage, extreme operating conditions and charge/discharge cycles that Solar applications require.



### SPECIFICATIONS

Cells per unit	6
Nominal voltage	12
Terminal Type	1/4" stainless steel stud
Capacity @ 77°F (25°C) to 1.75v.p.c.	91 AH (20 Hours) 105 AH (100 Hours)
kWh to 1.75 v.p.c.	1.082 (20 hrs) 1.279 (100 hrs)
Short circuit current	3366 amps
Max discharge rate (1 min rate)	419 amps
Impedance @ 77°F 25°C	4.30 milliohms
Electrolyte (S.G.)	1.300
CA (MCA) @ 32°F	940
Ideal operating temperature range	68°F (20°C) to 77°F (25°C)
Extended operating temperature range	Discharge: -40°F to +140°F Charge: -60°F to +160°F
Float Voltage	2.25 to 2.3 Volts Per Cell
Cycle Service Voltage	2.33 to 2.36 Volts Per Cell
Max charging rate Float - 15.6 amps	Cycle - 19 amps
Discharge Rate to 1.75 Volts Per Cell 10 hours - 8.4	3 hours - 24.1 5 hours - 15.6
Weight lbs	72
Length x Width x Height case (Height to the top of the terminals)	12.0" x 6.57" x 8.2" (9.31")

### FEATURES

- Advanced Gel Technology, provides deep cycle capability and better recharge profile throughout the life of the battery.
- Gas recombination greater than 99%.
- Sealed Non-spillable construction. Needs no water additions and will not allow electrolyte spills.
- Shock absorbent polypropylene plastic. Resistant to extreme temperatures and vibration.
- Operates at a low internal pressure.
- Thermally welded case to cover bond, eliminates the risk of acid and electrical leaks.
- Oversized internal components insures minimal voltage drop and more power availability.
- Each cell has a low pressure safety release venting system to prevent explosions, recognized per U.L. 924.
- Industrial grade battery plates.
- Puncture proof separator.
- Measured high vacuum acid fill, reduces electrical variability between cells.
- Can be used in any position, except upside down.
- Lifting handle.
- 100% recyclable materials.



**Power Battery Company, Inc.**

(973) 523-8630 • [www.powerbattery.com](http://www.powerbattery.com)

# POWER SOLAR SERIES

## PSG-12105

### DISCHARGE RATES IN AMPS @ 77°F ( 25°C )

Final V.P.C.	1 Hour	2	3	4	6	8	10	12	20	24	48
1.75	57.1	33.2	24.1	19	13.3	10.3	8.4	7.1	4.5	3.8	2

### BATTERY DIMENSIONS

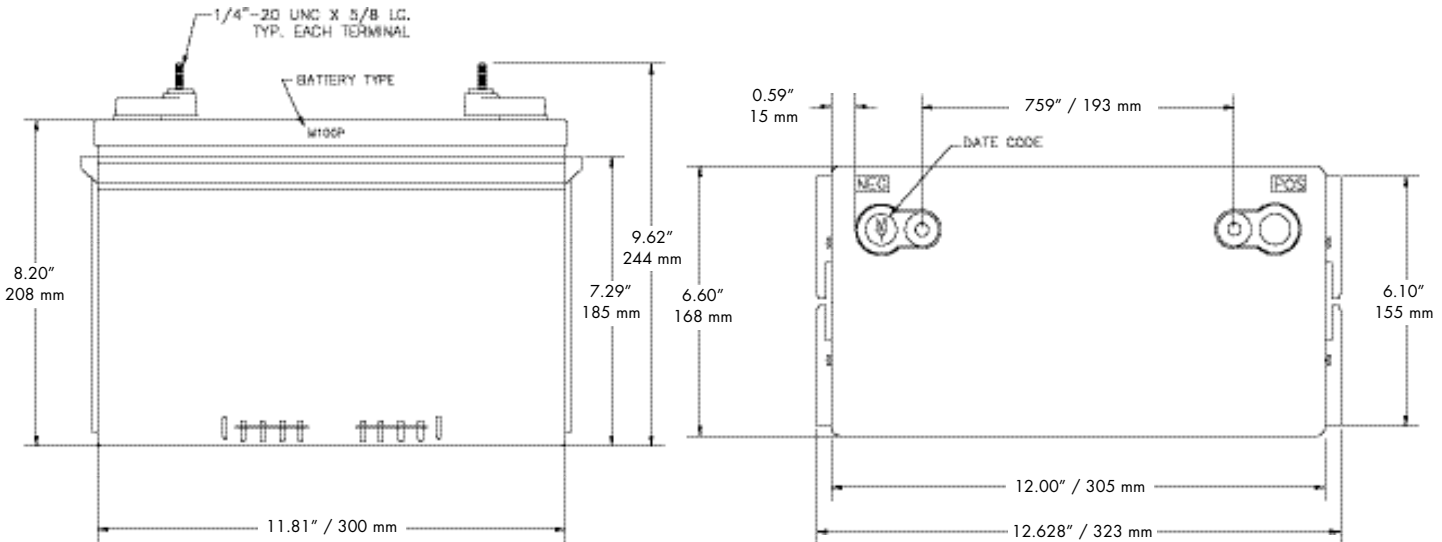

**SIDE VIEW**

**TOP VIEW**

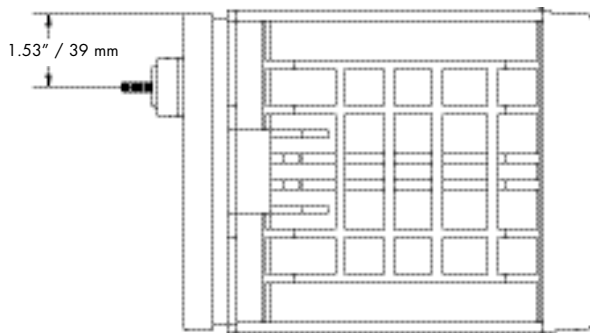

**SIDE VIEW**

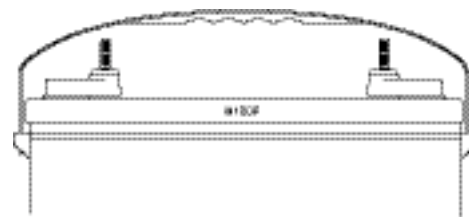

**FRONT VIEW  
WITH OPTIONAL HANDLE**

### CYCLE LIFE VS. DEPTH OF DISCHARGE

15% DOD	3000 cycles
25% DOD	2000 cycles
50% DOD	1100 cycles
80% DOD	600 cycles

### NO TRANSPORT RESTRICTIONS

- Surface transport. Classified as non-hazardous material as relates to DOT-CFR Title 49 part 171-189.
- Maritime transport. Classified as non-hazardous material as per IMDG amendment 27.
- Air transport. Complies with IATA/ICAO, special provision A67.



**U.S.A.**  
Power Battery Company, Inc.  
25 McLean Blvd.  
Paterson, N.J. 07514-1507  
Phone: (973) 523-8630  
Fax: (973) 523-3023  
E-mail: sales@powbat.com  
Website: www.powerbattery.com

**CANADA**  
Power Battery (Iberville) Ltd.  
770 Thomas Ave.  
St-Jean-sur-Richelieu, QC J2X 5E7  
Phone: (450) 346-3273  
Fax: (450) 346-8003  
E-mail: sales@powbat.com  
Website: www.powerbattery.com

**UK**  
Power Batteries Ltd.  
Premier Way, Abbey Park Ind. Estate  
Romsey, Hampshire, SO51 9AQ  
Phone: +44 (0)1794 835900  
Fax: +44 (0)1794 835910  
E-mail: sales@powbat.co.uk  
Website: www.powbat.co.uk