

FRONT ACCESS



**VALVE REGULATED
LEAD ACID BATTERY (V.R.L.A.)**



**ADVANCED ABSORBED GLASS
MAT TECHNOLOGY (A.G.M.)**



**LONG DURATION BATTERIES
DESIGNED FOR MAXIMUM LIFE**



The FT series of batteries are ideal for installations where space is at a premium. The front access design permits rapid installation and reduced maintenance time.

Features and Benefits

- Ten year design life in telecom float service.
- A recognized component of U.L.
- Valve regulated lead acid battery (VRLA).
- Absorbed glass mat technology (AGM) with gas recombination greater than 99%.
- Operates at a low internal pressure.
- Never needs watering; minimal maintenance.
- Shock absorbent thick wall construction.
- Advanced lead tin calcium alloy, reduces grid corrosion and promotes long battery life.
- Flame-retardant ABS plastic case and cover compliant with U.L.1778 V-0 with an Oxygen Limiting Index of greater than 28%.
- Cold forged nonporous terminal bushings; eliminate post leakage.
- Thermally welded case to cover bond; eliminates both acid and electrical leaks.
- Over-sized, through the partition inter-cell welds for minimal power loss.
- Flame arresting, low pressure safety release venting system for individual cells, recognized per U.L. 924.
- Measured high vacuum acid fill, reduces electrical variability between cells.
- Terminal and bussbar covers.

Options

- Custom wire harnesses.
- 10 volt version.
- High temperature retaining sleeves.

Specifications

Cells / Volts	6 cells / 12 volts
Terminal type	Threaded copper insert, 1/4"
Capacity @ 77°F (25°C)	89.6 AH (8 hrs) to 1.75 V.P.C.
Operating temperature range:	-40°C/-40°F to 60°C/140°F
Charging voltage / current:	2.27 to 2.30 volts per cell, constant voltage at a maximum current of C/4 amps.
Temperature compensation: Apply for temperature range of 0°C/32°F to 40°C/104°F.	Subtract 3mV/°C/cell or 1.7 mV/°F/cell, above 25°C/77°F. Add 3 mV/°C/cell or 1.7 mV/°F/cell, below 25°C/77°F.
Storage time from a fully charged condition:	6 months at 25°C/77°F. For each 9°C/15°F rise, reduce the storage time by half.
Self discharge rate	Less than 2% per month @ 25°C/77°F
AC ripple from charging source	1.5% peak to peak of float
Overall dimensions (inches, mm)	11.81" H x 15.25" L x 4.86" W 300mm H x 388mm L x 123mm W
Weight	68 lbs / 31.0 kg

Standards and Compliances

- UL Compliant
- NEBS Compliant
- EUROBAT,
10 year plus classification
- Tested in accordance with
 - BS6290 PART 4, 1987
 - Bellcore, TR-NWT-000766
 - ANSI, TI: 330

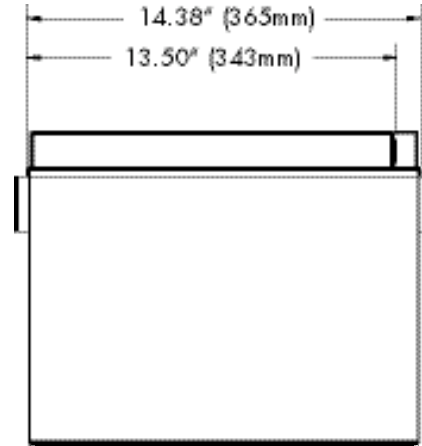
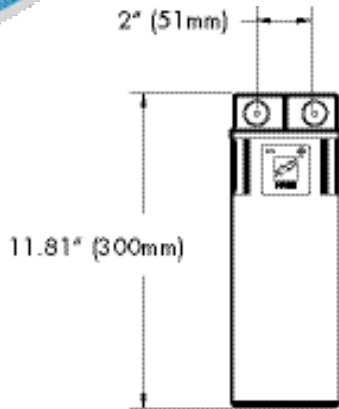
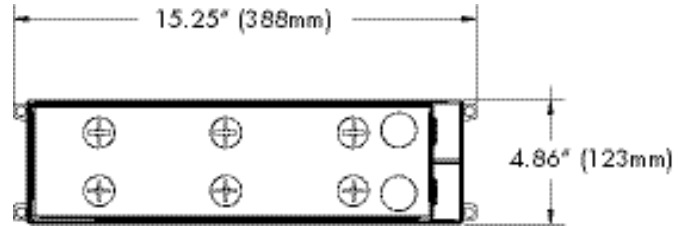

Hourly Discharge Rates in Amperes @ 77°F (25°C)

Discharge Hours	End Voltage Per Cell			
	1.90V	1.85V	1.80V	1.75V
1	48.5	53.5	56.2	57.5
1.5	35.5	38.9	40.7	41.6
2	28.6	31.1	32.5	33.1
3	21.0	22.7	23.5	24.0
4	16.8	18.1	18.7	19.1
5	14.2	15.2	15.7	16.0
6	12.4	13.2	13.6	13.8
7	11.0	11.7	12.0	12.2
8	10.1	10.7	11.0	11.2

Discharge Specifications

Constant power rating, Watts per battery @ 77°F (25°C) in minutes

Final V.P.C.	5	10	15	20	30	60
1.60	3314	2349	1832	1562	1196	764
1.67	3187	2259	1762	1502	1150	735
1.75	2957	2128	1655	1397	1088	720
1.80	2781	1924	1554	1273	1017	708

Rates subject to change without notice.

1666-2-0411

U.S.A.
Power Battery Company, Inc.
25 McLean Blvd.
Paterson, N.J. 07514-1507
Phone: (973) 523-8630
Fax: (973) 523-3023
E-mail: sales@powbat.com
Website: www.powerbattery.com

CANADA
Power Battery (Iberville) Ltd.
770 Thomas Ave.
Iberville, Québec, J2X 5E7
Phone: (450) 346-3273
Fax: (450) 346-8003
E-mail: powerbat@sympatico.ca
Website: www.powerbattery.com

UK
Power Batteries Ltd.
Premier Way, Abbey Park Industrial Estate
Romsey, Hampshire, SO51 9AQ
Phone: +44 (0)1794 835900
Fax: +44 (0)1794 835910
E-mail: sales@powbat.co.uk
Website: www.powbat.co.uk

ITALY
Power Battery Srl
Via Locatelli 105
20046 Biassono MI - ITALY
Phone: +(39) 039 2324571
Fax: +(39) 039 2499200
E-mail: calberti@powbat.it
Website: www.powbat.it